

NCL 型

NCL TYPE

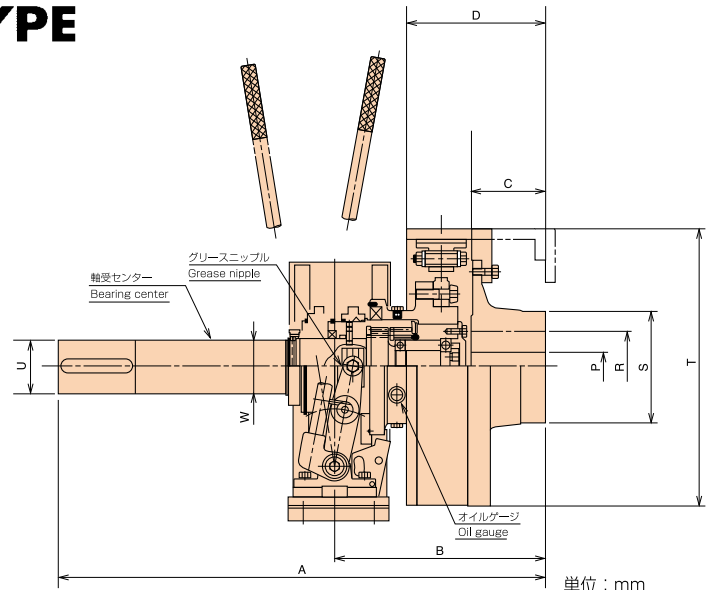
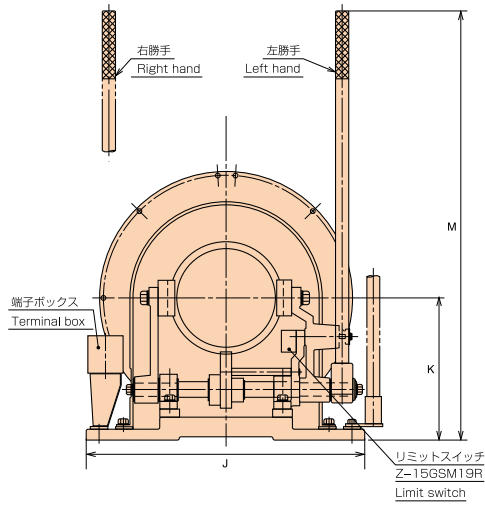

単位 : mm
unit : mm

型式 MODEL TYPE	記号 MARK	A	B	C	D	J	K	M	φP	φR	φS	φT	φU	φW	製品質量 kg WEIGHT
NCL-136		853	335.5	90	200	600	280	673	30	85	143	367	70	85	145
NCL-156		1,008	421.5	127	243	600	280	673	45	115	178	414	85	95	195
NCL-186		1,105	427.5	152	286	630	320	913	65	150	230	494	95	110	290
NCL-218		1,148	470.5	152	284	630	320	913	65	150	230	576	95	110	350
NCL-248		1,330	522.0	153	331	680	320	965	70	165	254	656	125	150	520
NCL-308		1,432	614.0	203	381	740	370	1,126	75	200	305	817	140	190	890

NCL-1B 型

NCL-1B TYPE

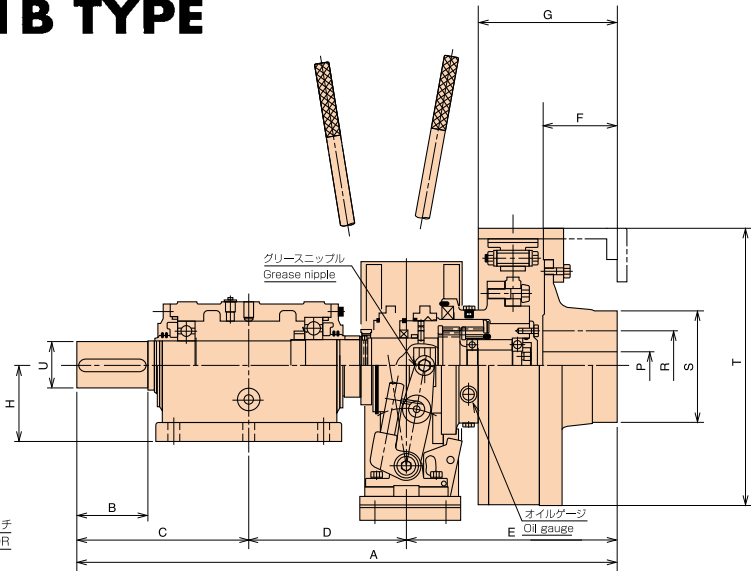
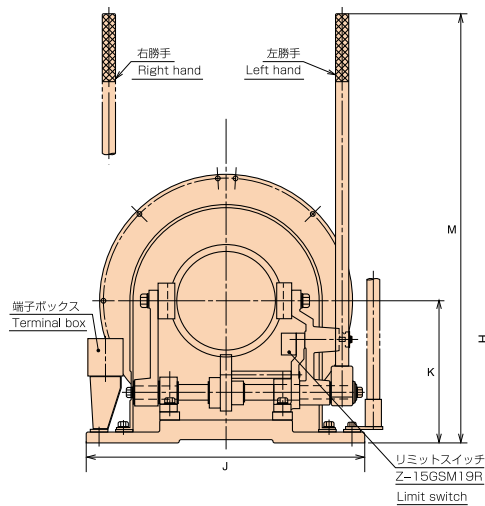

単位 : mm
unit : mm

型式 MODEL TYPE	記号 MARK	A	B	C	D	E	F	G	H	J	K	M	φP	φR	φS	φT	φU	製品質量 kg WEIGHT
NCL1B-136		853	90	260	269.5	335.5	90	200	125	600	280	673	30	85	143	367	70	205
NCL1B-156		1,008	110	300	286.5	421.5	127	243	140	600	280	673	45	115	178	414	85	255
NCL1B-186		1,105	145	355	322.5	427.5	152	286	155	630	320	913	65	150	230	494	95	350
NCL1B-218		1,148	145	355	322.5	470.5	152	284	155	630	320	913	65	150	230	576	95	425
NCL1B-248		1,330	160	418	390.0	522.0	153	331	190	680	320	965	70	165	254	656	125	600
NCL1B-308		1,432	170	430	388.0	614.0	203	381	215	740	370	1,126	75	200	305	817	140	970

NCL-2B型 NCL-2B TYPE

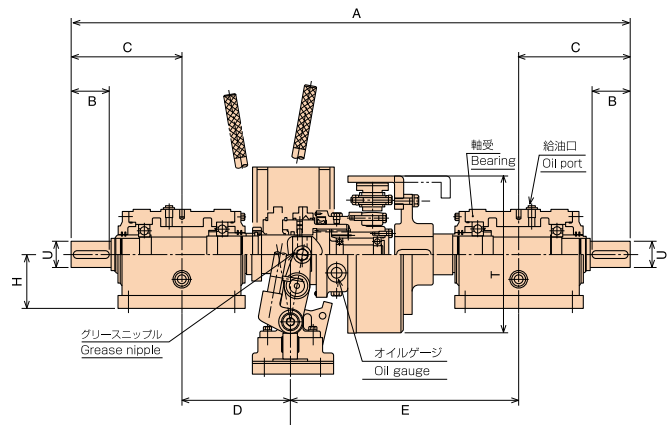
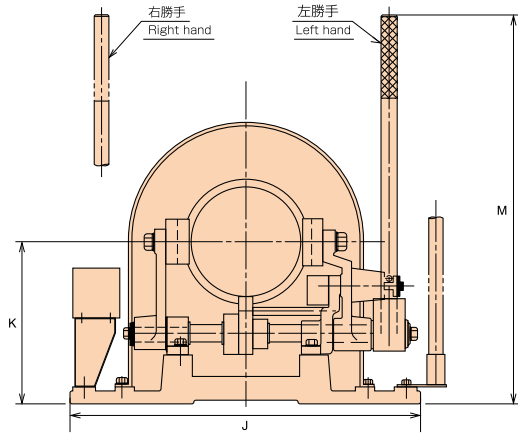

単位：mm
unit：mm

型式 MODEL TYPE	記号 MARK	A	B	C	D	E	H	J	K	M	φT	φU	製品質量 kg WEIGHT
NCL2B-136		1,303	90	260	269.5	513.5	125	600	280	673	367	70	265
NCL2B-156		1,498	110	300	286.5	611.5	140	600	280	673	414	85	315
NCL2B-186		1,690	145	355	322.5	657.5	155	630	320	913	494	95	410
NCL2B-218		1,752	145	355	322.5	719.5	155	630	320	913	576	95	495
NCL2B-248		2,075	160	418	390.0	849.0	190	680	320	965	656	125	680
NCL2B-308		2,122	170	430	388.0	874.0	215	740	370	1,126	817	140	1,050

NCLU型 NCLU TYPE

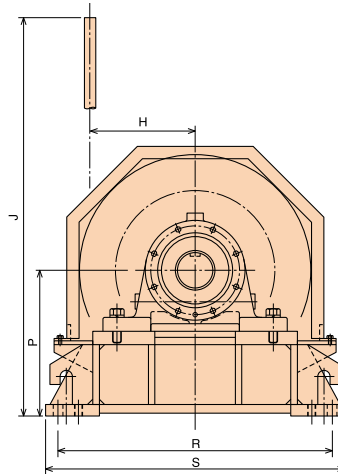
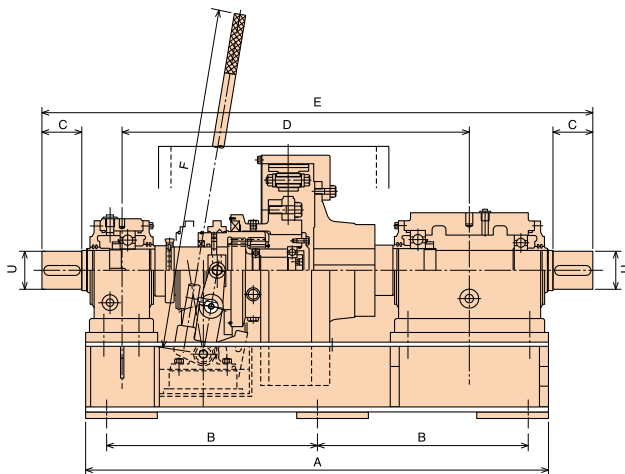

単位：mm
unit：mm

型式 MODEL TYPE	記号 MARK	A	B	C	D	E	F	H	J	P	R	S	φU	製品質量 kg WEIGHT
NCLU-136		960	430-2	90	720	1,160	550	215.5	530	300	550	600	70	350
NCLU-156		1,100	485-2	100	815	1,320	550	220.5	580	320	550	600	85	430
NCLU-186		1,200	525-2	100	915	1,420	800	232.0	620	320	600	650	95	800
NCLU-218		1,210	530-2	120	920	1,470	800	232.0	700	350	600	680	95	850
NCLU-248		1,340	390-2	160	1,010	1,680	850	255.5	780	400	680	800	125	1,150
NCLU-308		1,520	450-2	170	1,130	1,880	1,000	283.0	940	480	800	950	140	2,100